

Merging Technologies AES67 Solution for Analog Devices Sharc SoCs

Introducing a scalable, high performance AES67 solution for the ProAV Industry

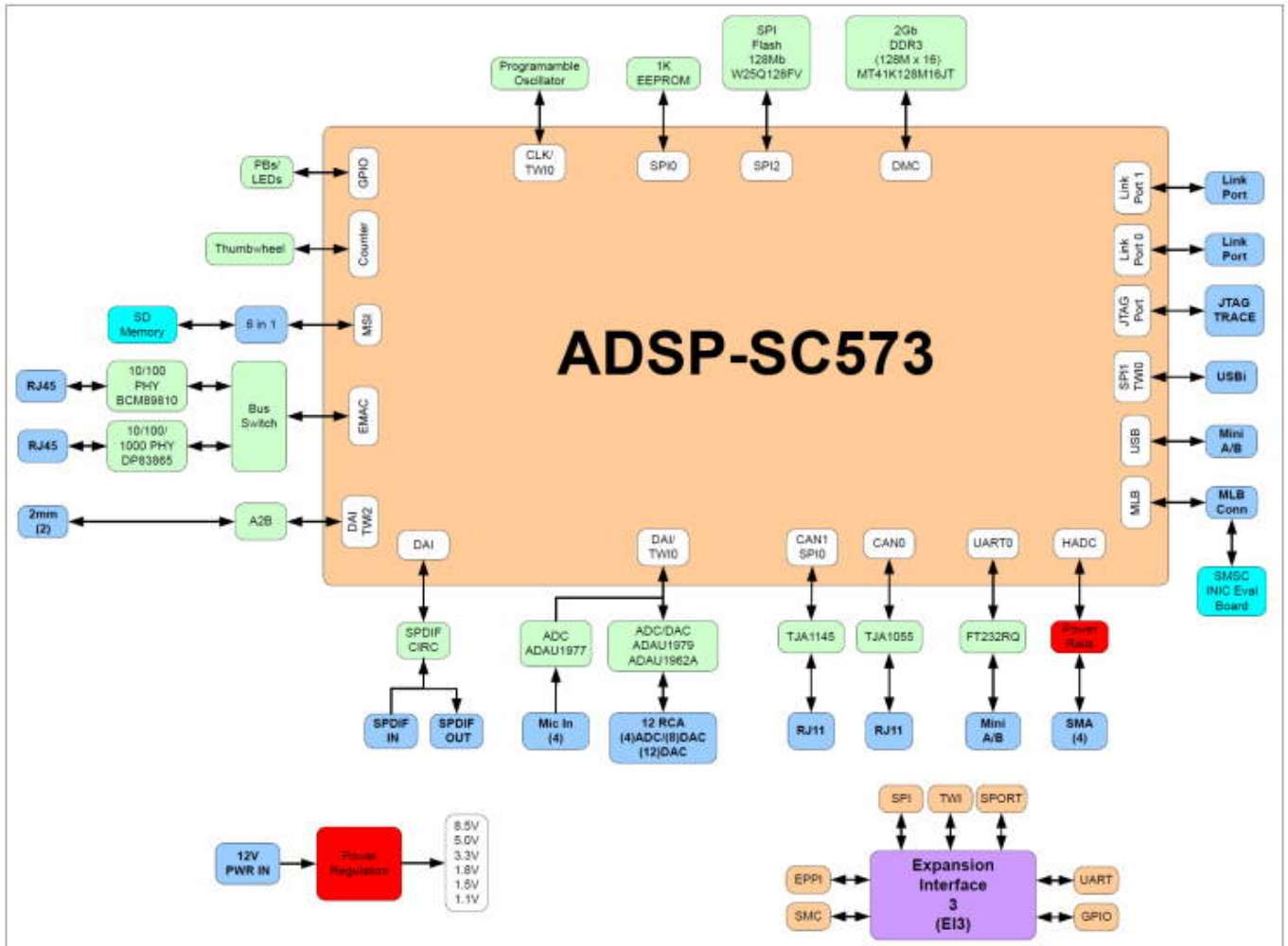

Merging Technologies today announces the availability of its AES67 embedded solution for the ADSP-SC5xx SHARC series of System on Chips (SoCs) from Analog

Monday, 09 May 2022 13:44

Devices, Inc. (ADI). Merging Technologies' experience in the audio over IP (AoIP) field (RAVENNA/AES67) and ADI's experience in unified communications and pro-audio applications, has led to a collaboration that broadens the range of AoIP solutions for manufacturers of electronics and ultimately integrators.

Merging has a long history of delivering OEM solutions, both software and hardware, especially with the ZMAN AES67 RAVENNA boards, which are currently used by an ever-growing list of manufacturers and are naturally a key component in Merging's own Anubis and Hapi MKII. Merging has been one of the driving forces of RAVENNA since the very beginning.

Availability of this Audio over IP technology allows a much broader audience to access this state-of-the-art AES67 technology and enable OEMs to design AES67-based products using ADI's ADSP-SC5xx SHARC series of SoCs.

The ADSP-SC5xx SoCs integrate an Arm Cortex® Core, providing a control processor for enhanced integrated peripherals including Gigabit Ethernet with IEEE1588 and USB. The ADSP-SC5xx SoCs also integrate a single- or dual-SHARC+ DSP floating-point core with an on-chip hardware accelerator. This combination offers flexible audio connectivity and performance scalability across different pin-to-pin compatible products, while providing several on-chip memory options.

By offering both single and dual core options, the SoCs will address from 1 to 64 channel configurations. For those looking for even more channels, Merging still continues to supply their own ZMAN boards.

"Analog Devices is pleased to collaborate with Merging Technologies to offer developers the embedded AES67 solution with our ADSP-SC5xx SoCs," said David Dashefsky, Director for Consumer AV at Analog Devices. "We can now enable an ecosystem of SHARC DSPs with AES67 connectivity, providing a powerful and compelling solution for the professional AV industry."

"Merging is delighted to be part of this venture that will democratize AES67. Providing solutions for lower channel counts was always something we wanted but had no means to achieve," commented Claude Cellier, Merging's President. "ADI has the means to do this, and we are confident that this collaboration will contribute greatly to the expansion of AoIP in the pro-audio universe."

www.merging.com